

THIS DRAWING IS UNPUBLISHED. RELEASED FOR PUBLICATION MAY, 2006.
 © COPYRIGHT 2006 BY TYCO ELECTRONICS CORPORATION. ALL RIGHTS RESERVED.

LOC	DIST	REVISIONS					
E	B	P	LTR	DESCRIPTION	DATE	DWN	APVD
		C		ECR-06-012053	19MAY06	JMS	FWK

NOTES:

- 1 PACK IN ACCORDANCE WITH AMP SPEC 107-3275
- 2 100 TRAY PACK IN ACCORDANCE WITH AMP SPEC 107-3275
- 3 Au PLATING
- 4 Ni PLATING
- 5 THIS ITEM MUST BE WHITE
- 6 HAND TOOL : 9-1478240-0
- 7 DIE SET : 9-1478242-0
- 8 ELECTRICAL CHARACTERISTICS
 FREQUENCY RANGE: DC - 11 GHz
 NOMINAL IMPEDANCE: 50 Ohm
 INSULATION RESISTANCE: 5000 MOhm
 WORKING VOLTAGE: 1000 Volts RMS at Sea Level
 DIELECTRIC WITHSTAND VOLTAGE: 2500 Volts RMS Max
 CONTACT RESISTANCE:
 CENTRE CONTACT: 1.00 mOhm Max
 OUTER CONTACT: 1.00 mOhm Max
 VSWR @ 4GHz: 1.30:1 Max
 INSERTION LOSS dB @ x 4 GHz: 0.30 Max
- 9 MECHANICAL CHARACTERISTICS
 COUPLING NUT RETENTION FORCE: 445N Min
 CABLE RETENTION FORCE: 170N Min
 DURABILITY: 500 Cycles Min
- 10 ENVIRONMENTAL CHARACTERISTICS
 OPERATING TEMPERATURE: -65 to +165 DegC
- 11 FOR TECHNICAL DATA REFER TO YOUR LOCAL TYCO ELECTRONICS SALES OFFICE
- 12 ALL DIMENSIONS ARE NOMINAL FOR REFERENCE ONLY UNLESS OTHERWISE STATED

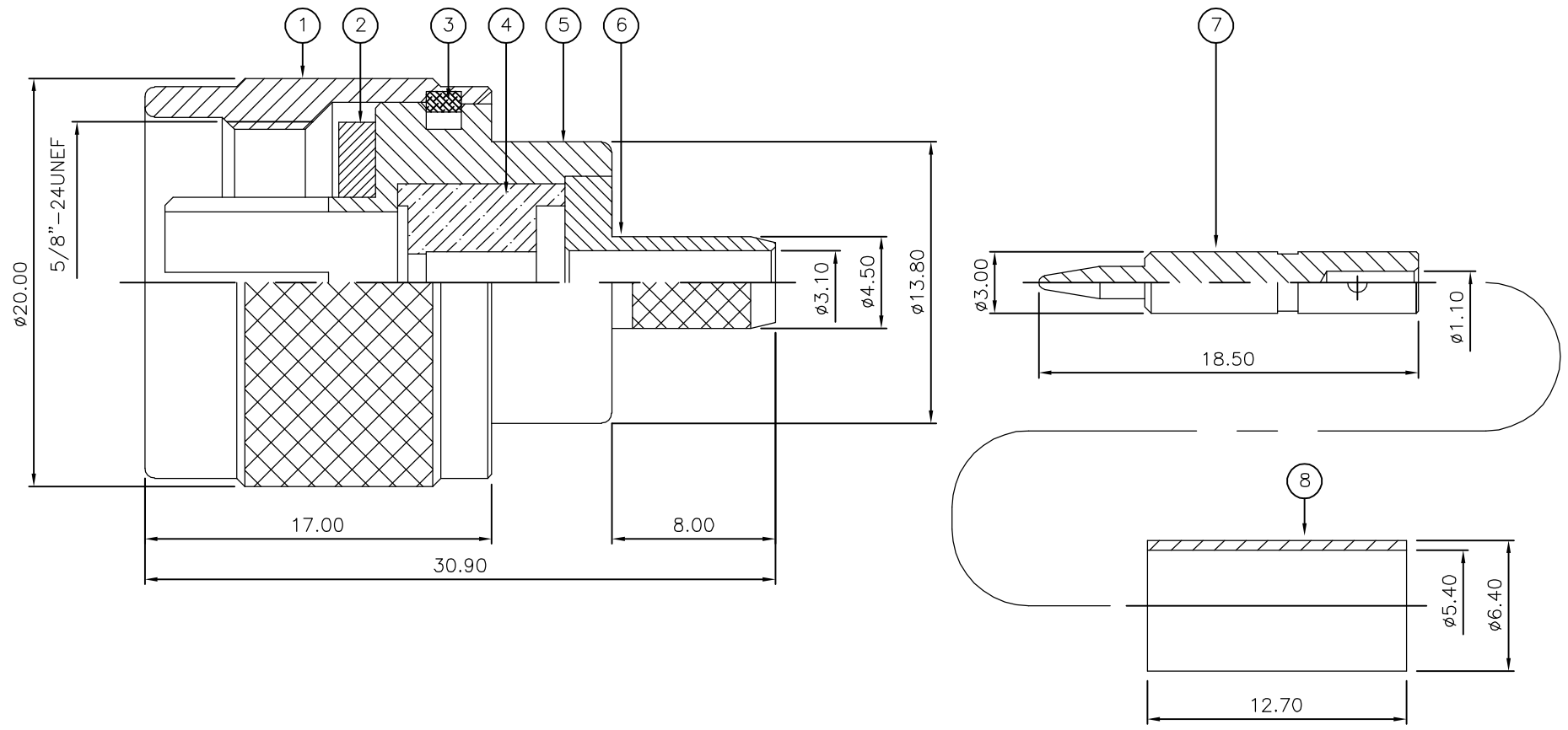

QTY	UNIT	MATERIAL	DESCRIPTION	ITEM
1	1	BRASS	FERRULE	8
1	1	BRASS	CONTACT	7
1	1	BRASS	CHASSIS	6
1	1	BRASS	BODY	5
1	1	PTFE	INSULATION	4
1	1	BRASS	CIRCLIP	3
1	1	SILICONE RUBBER	GASKET	2
1	1	BRASS	COUPLING NUT	1
6--0	1--0	MATERIAL	DESCRIPTION	ITEM

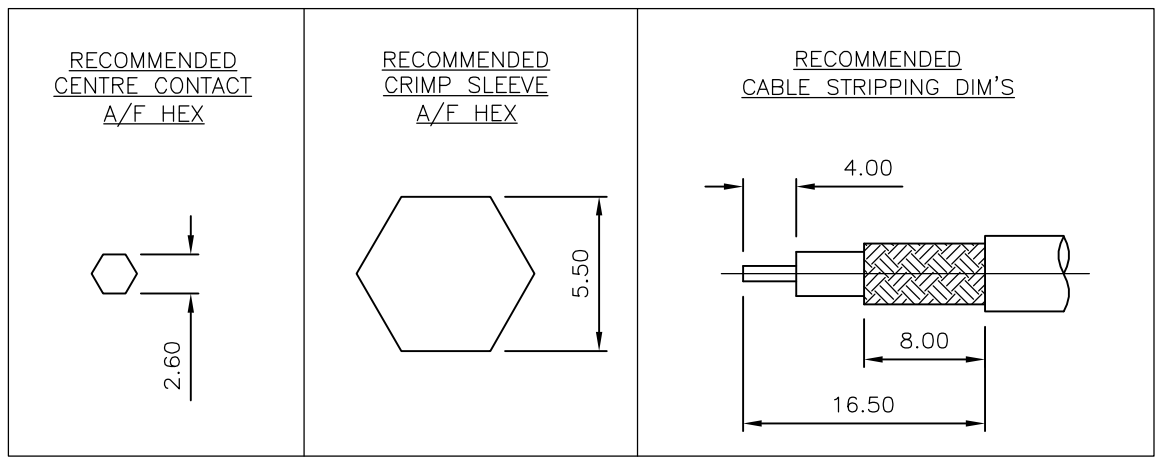

THIS DRAWING IS A CONTROLLED DOCUMENT.

DWN	J.SANDWELL	19MAY06
CHK	S.PARLOW	19MAY06
APVD	F.WHEELER-KING	19MAY06
PRODUCT SPEC	-	
APPLICATION SPEC	-	
WEIGHT	-	
CUSTOMER DRAWING	-	

DIMENSIONS: mm
 TOLERANCES UNLESS OTHERWISE SPECIFIED:
 0 PLC ± -
 1 PLC ± -
 2 PLC ± -
 3 PLC ± -
 4 PLC ± -
 ANGLES ± -
 FINISH -

tyco Electronics Tyco Electronics Corporation
 Bideford EX39 4HE
 NAME: TYPE 'N' STRAIGHT PLUG CRIMP 50 OHM
 RG58C/U, 141A/U, URM43, 76, KX 15
 SIZE: A3 CAGE CODE: 00779 DRAWING NO: C-1337631 RESTRICTED TO: -
 SCALE: NTS SHEET: 1 OF 1 REV: C